

SHEET INDEX NOT TO SCALE

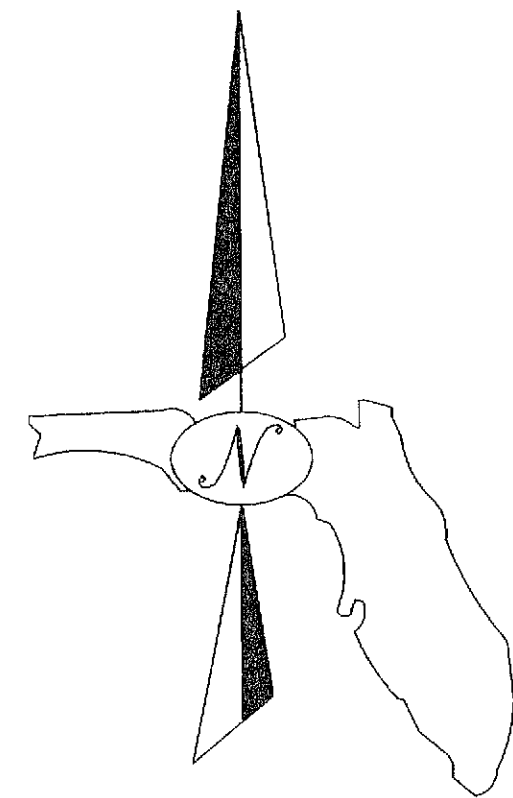

# PARCEL 32, P.U.D.

A PLANNED UNIT DEVELOPMENT  
BEING A PLAT OF A PORTION OF THE NORTHEAST ONE-QUARTER OF  
SECTION 29, TOWNSHIP 41 SOUTH, RANGE 43 EAST,  
PALM BEACH COUNTY, FLORIDA

THIS INSTRUMENT PREPARED BY  
DAVID P. LINDLEY  
OF  
CAULFIELD and WHEELER, INC.  
SURVEYORS - ENGINEERS - PLANNERS  
7301-A WEST PALMETTO PARK ROAD, SUITE 100A  
BOCA RATON, FLORIDA 33433 - (561)392-1991  
JANUARY - 2010

STATE OF FLORIDA  
COUNTY OF PALM BEACH  
THIS PLAT WAS FILED FOR  
RECORD AT \_\_\_\_\_ M.  
THIS \_\_\_\_\_ DAY OF \_\_\_\_\_  
A.D. 20\_\_\_\_ AND DULY RECORDED  
IN PLAT BOOK \_\_\_\_\_ ON  
PAGES \_\_\_\_\_ AND \_\_\_\_\_

SHARON R. BOCK  
CLERK AND COMPTROLLER

BY: \_\_\_\_\_  
DEPUTY CLERK

MATCHLINE SHEET 11 OF 18

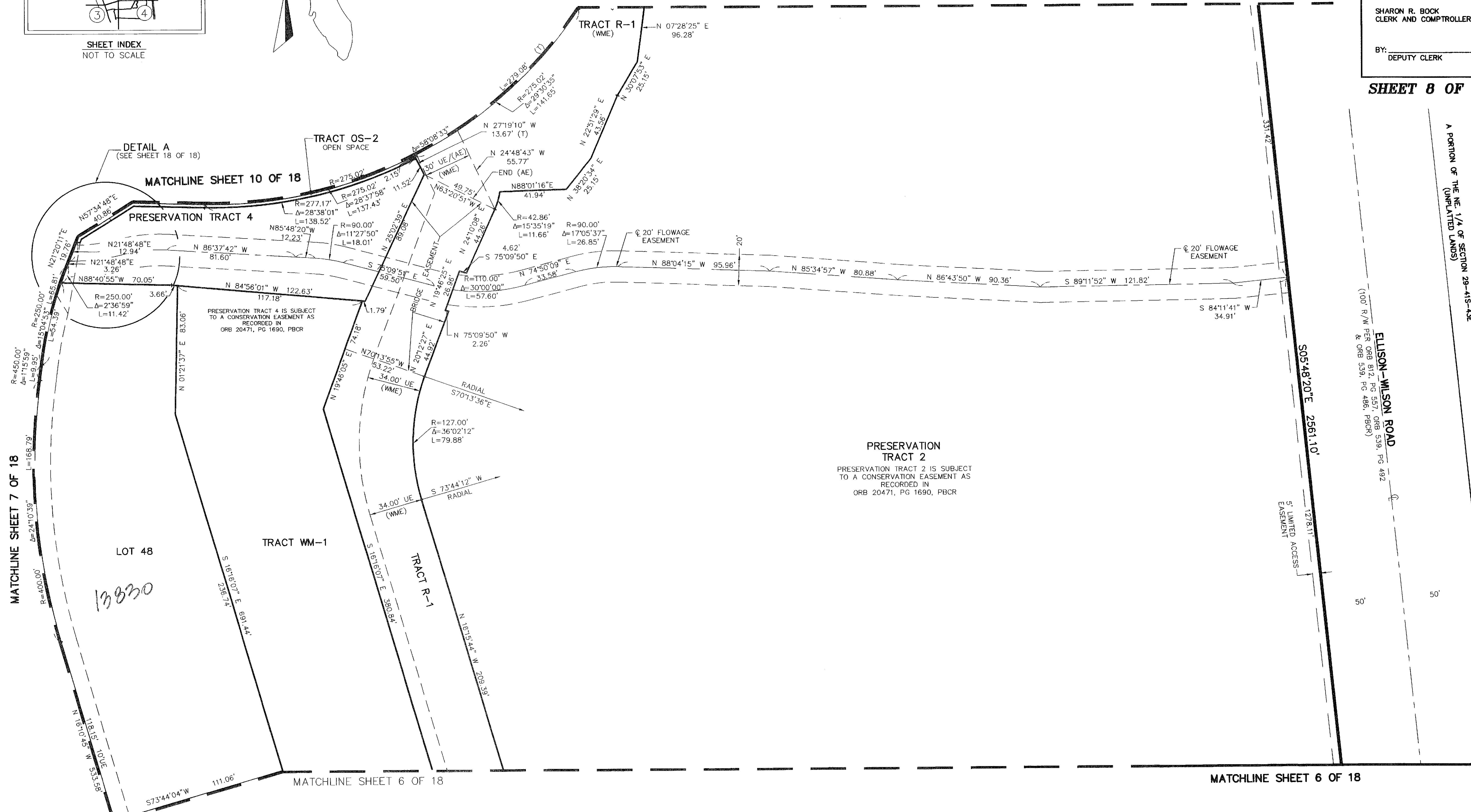

MATCHLINE SHEET 7 OF 18

LOT 48

13830

MATCHLINE SHEET 6 OF 18

MATCHLINE SHEET 6 OF 18

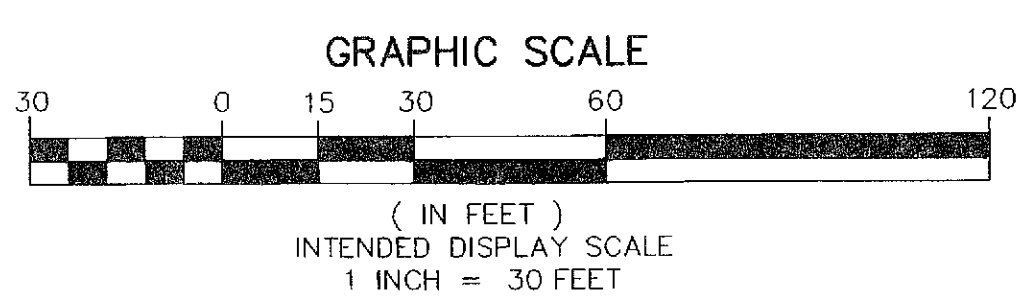

NOTE:  
PRESERVATION TRACTS 1, 2, 3, 4, 5 AND 6 AS SHOWN HEREON, ARE HEREBY DEDICATED TO NORTHERN PALM BEACH COUNTY IMPROVEMENT DISTRICT (NPBCID), ITS SUCCESSORS AND ASSIGNS, FOR CONSERVATION AREAS AND IS THE PERPETUAL MAINTENANCE OBLIGATION OF SAID NPBCID, ITS SUCCESSORS AND ASSIGNS, WITHOUT RECOURSE TO PALM BEACH COUNTY, AS PER ARTICLE 14.C, OF THE PALM BEACH COUNTY LAND DEVELOPMENT CODE, THE TRACTS ARE SUBJECT TO A CONSERVATION EASEMENT RECORDED IN OFFICIAL RECORDS BOOK 20471, PAGES 1690 THROUGH 1744 OF THE PUBLIC RECORDS OF PALM BEACH COUNTY, FLORIDA.

A PORTION OF THE NE 1/4 OF SECTION 29-41S-43E (UNPLATTED LANDS)

ELLISON-WILSON ROAD  
(100' R/W PER ORB 812, PG 537, ORB 539, PG 492 & ORB 539, PG 496, PBCR)

5' LIMITED ACCESS EASEMENT

S05°48'20"E 2561.10'

50'

50'